

Sunkist

Commercial Juicer #8
Parts Information

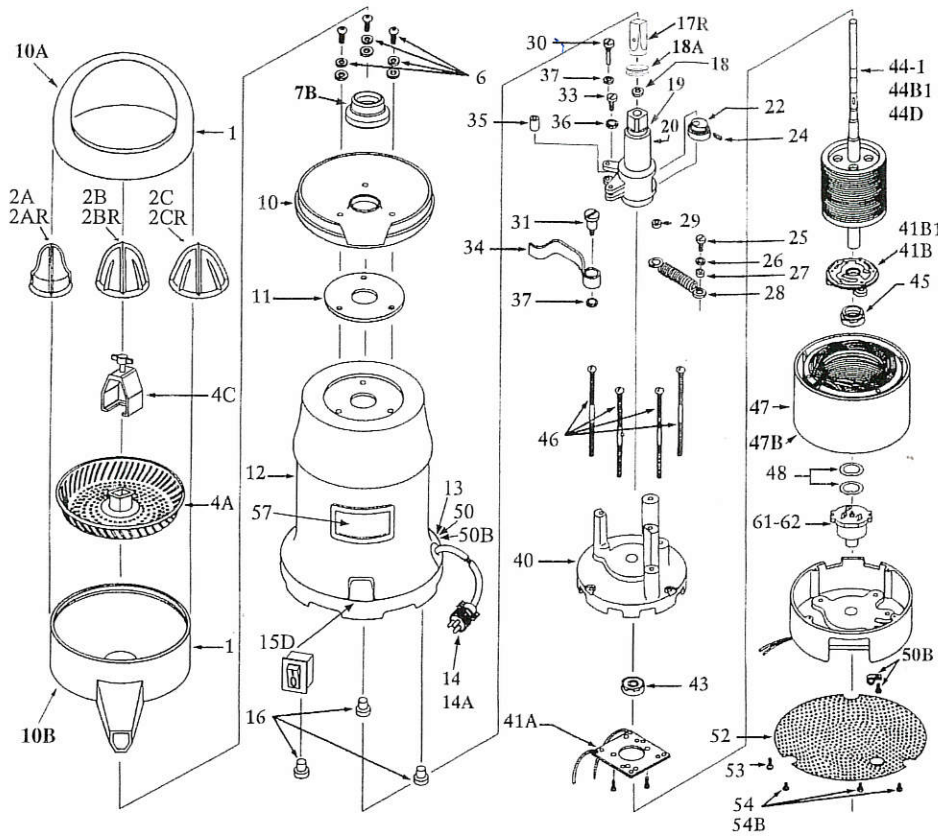

Specifications

Chrome-plated steel housing.
Corrosion proof plastic dome, spout & bowl support.

Safe...Listed by Underwriters Laboratories, CSA International®, NSF International® & VDE as applicable.

Shipping weight37 pounds
Net weight31 pounds
Overall dimensions ...17" high 8" diameter
Horsepower1/4
Cube1.12
Carton size22 3/4" x 9 3/4" x 9 3/4"

Part Number	Description
1.	Plastic Bowl Assembly incl. dome (10A), spout (10B) & bowl support (10)
2.	Extracting Bulb Set w/metal insert (only use with 17 or 17C) A. Lemon/Lime fits #8 model B. Orange fits #7 & #8 models C. Grapefruit fits #7 & #8 models
2R.	Extracting Bulb Set w/o metal insert (only use with 17R) AR. Lemon/Lime BR. Orange CR. Grapefruit
3.	Lever Lock & Screws for Strainer (for #7 juicer - not illustrated)
4.	Strainer w/Lever Lock & Screws (for #7 juicer - not illustrated)
4A.	Strainer for #8 juicer
4C.	Strainer Puller for #8 juicer
6.	Bowl Support Screws, Spacers, Washers (set of 3)
7.	Umbrella Ring w/Set Screw & Gasket (not illustrated)
7B.	Umbrella Seal (only for use on grooved eccentric housings, replaces 7, 8 & 9)
8	Umbrella Ring Set Screw (incl'd w/7) (not illustrated)
9.	Umbrella Ring Gasket (incl'd w/7) (not illustrated)
10.	Plastic Bowl Support only (incl'd w/#1)
10A.	Plastic Dome only (incl'd w/#1)
10B.	Plastic Spout only (incl'd w/#1)
11.	Bowl Support Gasket
12.	Chrome Motor Housing
13.	Electric Cord Bushing (use w/ 50B)
14.	Electric Cord 115/60
14A.	Rubber Cord - Export

Part Number	Description
15.	Toggle Switch w/Switch Guard (not illustrated)
15D.	Rocker Switch w/Switch Seal
15E.	Connectors for 14A & 15D (set of 4) (not illustrated)
16.	Rubber Feet (set of 3)
17.	Shaft Tip w/Pin (not illustrated) (only use with 2A, 2B, and/or 2C)
17C.	Shaft Tip w/Pin (graduated tip) (not illustrated) (only use with 2A, 2B, and/or 2C)
17R.	Shaft Tip w/Pin (flat tip) (only use with 2AR, 2BR, and/or 2CR)
18.	Eccentric housing Gasket (incl'd w/#20)
18A.	Shaft Tip Gasket (fits 17C and 17R)
19.	Brass Tube
20-7.	Eccentric Housing w/Bearings, Gasket & Brass Tube #7 Juicer
20-8.	Eccentric Housing w/Bearings, Gasket & Brass Tube #8 Juicer
20-8C.	Eccentric Mechanism #8 Juicer
22.	Ecc. Hub w/Bearing & Screw
24.	Ecc. Hub Hex Screw 1/4-20x1/2
25.	Spring Screw to Motor Mount 10-32
26.	Lock Washers incl. 36 (2) & 37 (3)
27.	Bronze Bushing Coil Spring to Motor Mount 5/64 x 3/8 x 1/4
28.	Coil Spring
29.	Bronze Bushing Coil Spring to Ecc. Housing 5/64 x 3/8 x 3/16
30.	Arm Screw - Small 1/4-32 x 1 1/16
31.	Arm Screw - Large 1/4-20 x 29/32
33.	Spring Screw to Ecc. Housing 1/4-32
34.	Eccentric Arm
35.	Ecc. Arm Bronze Bushing 1/2 x 3/16 x 5/16
36.	Lock Washer, 3/16, Internal Tooth
37.	Lock Washer, 1/4, Internal Tooth

Part Number	Description
40.	Top Motor Casting
41A.	Stationary Motor Switch - Howell Motor
41B.	Centrifugal Motor Switch 115V - Howell Motor
41B1.	Centrifugal Motor Switch 230V - Howell Motor
43.	Motor Bearing Top or Bottom - Howell
44-1.	Rotor w/shaft Howell Motor 115/60
44B1.	Rotor w/shaft Howell Motor 230/50
44D.	Rotor w/shaft Howell Motor 230/60
45.	Motor Bearing Top or Bottom - Ohio
46.	Motor Screws (set of 4)
47.	Stator (winding) - Howell Motor 115/60
47B.	Stator (winding) - Howell Motor 230/50
48.	Tension Washers - Howell Motor (set of 2)
50.	Electric Cord Strain Relief for J-2
50B.	Electric Cord Strain Relief for J-1, J-4 & J-5
52.	Perforated Base Plate
53.	Ground Screw w/Lock Washer for J-1, J-4 & J-5 (set of 2)
54.	Base Plate Screws for J-1, J-4 & J-5 (set of 3)
54B.	Tamper Proof Screws for Base Plate on J-2 (set of 3)
57.	Logo Plate, Label and Fasteners
61.	Thermal Overload 115/60 - Howell Motor
62.	Thermal Overload 230/50 - Howell Motor
64.	Model #7 or #8 Motor - 115/60 4.3 amp - 1725 rpm
65.	Model #7 or #8 Motor - 230/50 2.5 amp - 1425 rpm
67	Model #7 or #8 Motor - 230/60 2.5 amp - 1725 rpm

87 R09-06

Sunkist is a registered trademark of ©2006 Sunkist Growers, Inc., Sherman Oaks, CA 91423, U.S.A. All Rights Reserved.

KOLB GesmbH
Stoberweg 2
A-6812 Meiningen
Tel.: 0 55 22/37 500-0
Fax: 0 55 22/37 389
e-mail: info@kolb.at
www.kolb.at



Erfolg für die gute Backstube